

OLMO

MULTI-POSITION AHU **OUTDOOR UNIT**

CENTRAL SPLIT AIR HANDLER AIR CONDITIONING SYSTEM

Installation Manual

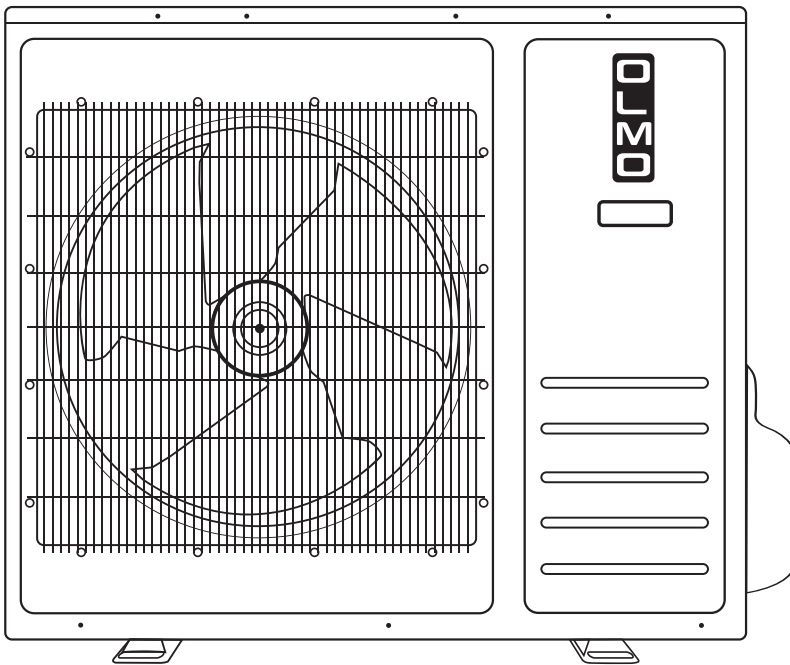

Model:
OS-EAH36-230VO

IMPORTANT NOTE:

Thank you for purchasing our air conditioning system. Please read this manual carefully before operating your new air conditioning units. Make sure to save this manual for future reference.

Contents

Safety precautions	1
Refrigerant flow diagram	3
Diagram of refrigerant cycle & wiring	3
Refrigerant flow diagram	3
Electrical wiring diagram	3
Installation instructions	4
Transportation and handling before installation	4
Installation locations selection	4
Drainage elbow and drain hose installation	5
Outdoor unit installation	5
Refrigerant piping	6
Wiring	9
Test run	11

NOTE:

- This air conditioner has been designed for the following temperatures. Operate the heat pump air-conditioner within this range.

Mode	Outdoor operation temperature range [°F (°C)]	
	Maximum	Minimum
Cooling Operation	122 (50)	5 (-15)
Heating Operation	75 (24)	-13 (-25)

- Storage condition: Temperature -13~140°F (-25~60°C)
Humidity 30%~80%

Safety precautions

1. This air conditioner uses new refrigerant HFC (R410A).
2. Since the max. working pressure is 550 psig (3.8MPa) [R22:450 psig (R22:3.1MPa)], some of the piping and installation and service tools are special.
3. This air conditioner uses power supply: 208/230V ~, 60Hz.
4. The outdoor unit must be installed with indoor unit equipped with TXV and ensure that the TXV can be opened to the maximum angle while running heating mode.
5. The outdoor unit must be matched with indoor unit with refrigerant R410A.
6. For 24K outdoor unit, it must be connected with 18K~24K indoor units.
For 36K outdoor unit, it can be connected with 30K~36K indoor units.
For 48K outdoor unit, it can be connected with 42K~48K indoor units.
For 60K outdoor unit, it can be connected with 42K~60K indoor units.
7. Specified filter drier is required on the liquid pipe when connecting the units.
8. Be sure that servicing equipment and replacement components are applicable for R-410A refrigerant.
9. Do not discharge R410A refrigerant into the air, and when recover it, the cylinder service pressure rating must be over 550 psig. R410A refrigerant systems should be charged with liquid refrigerant and the service pressure rating of the hoses used must be over 750 psig.
10. Leak detectors should be designed to detect HFC refrigerant.
11. R410A refrigerant is only compatible with POE oils, which could absorb moisture rapidly, so do not expose it to the air, in case that it damages certain plastics materials.
12. Replace all the filter driers after maintenance.

Please read these SAFETY PRECAUTIONS carefully to ensure correct installation.

- Be sure to use a dedicated power circuit, and do not put other loads on the power supply.
 - Be sure to read these SAFETY PRECAUTIONS carefully before installation.
 - Be sure to comply with SAFETY PRECAUTIONS of installation manual, because it contains important safety issues. Definitions for identifying hazard levels are provide below with their respective safety symbols.
- ⚠ **WARNING:** Hazards or unsafe practices which COULD result in severe personal injury or death.
- ⚠ **CAUTION:** Hazards or unsafe practices which COULD result in minor personal injury or product or property damage.
- Please carefully file indoor and outdoor unit manual away for future reference.

⚠ WARNING

- Installation should be performed by a qualified personnel.
Improper installation may cause water leakage, electrical shock or fire.
- Install the air conditioner on a solid base that can support the unit weight.
An inadequate base or incomplete installation may cause injury if the unit falls off the base.
- Use the specified type of wire for electrical connections safely between the indoor and outdoor units.
And firmly clamp the interconnecting wires so their terminals receive no external stresses.
- For wiring, use a cable long enough to cover the entire distance with no connection.
And do not connect multiple devices to the same AC power supply.
Otherwise, it may be due to bad contact, poor insulation, exceed the allowable current and cause a fire or electric shock.
- After all installation is completed, check to make sure that no refrigerant is leaking out.
If the refrigerant gas leakage to the interior, and the heater, stove flame touching it, will generate harmful substances.
- Perform the installation securely referring to the installation manual.
Incomplete installation could cause a personal injury due to fire, electric shock, the unit falling or leakage of water.
- In accordance with the installation instructions for electrical work, please be sure to use a dedicated line.
- If the power supply circuit capacity or electrical work is not in place, may cause a fire or electric shock.
- Attach the electrical cover to the indoor unit and the service panel to the outdoor unit securely.

Safety precautions

- If the electrical covers on the indoor unit or the service panel of the outdoor unit are not attached securely, it could result in a fire or an electric shock due to dust water, etc.
- Please be sure to cut off the main power supply before the installation of indoor electronic PCB or wiring. Otherwise, it will cause electric shock.
- The device should be in accordance with the state provisions for installation wiring.
- The outdoor machine installation location should pay attention to the protection, avoid people or other small animals contact with electrical components, please keep the outdoor unit of the surrounding environment clean and tidy.
- When installing or relocating the unit, make sure that no substance other than the specified refrigerant (R410A) enters the refrigerant circuit.
Any presence of foreign substance such as air can cause abnormal pressure rise or an explosion.



- Perform grounding
Does not connect the earth wire to a gas pipe, water pipe, lightning rod or telephone earth wire. Defective grounding could cause an electric shock.
- Do not install the unit in a place where an inflammable gas leaks.
If gas leaks and accumulates in the area surrounding the unit, it could cause an explosion.
- Fasten a flare nut with a torque wrench as specified in this manual.
When fastened too tight, a flare nut may break after a long period and cause a leakage of refrigerant.
- Install an earth leakage breaker depending on the installation place (where it is humid).
If an earth leakage breaker is not installed, it could cause an electric shock.
- Perform the drainage/piping work securely according to the installation manual.
- If there is a defect in the drainage/piping work, water could drop from the unit and household goods could be wet and damaged.

Safety instructions

- Do not let air enter the refrigeration system or discharge refrigerant when moving the air conditioner.
- This appliance is not intended for use by persons (including children) with reduced physical, sensory or mental capabilities, or lack of experience and knowledge, unless they have been given supervision or instruction concerning use of the appliance by a person responsible for their safety.
- Children should be supervised to ensure that they do not play with the appliance.
- If the supply cord is damaged, it must be replaced by the manufacturer, its service agent or similarly qualified persons in order to avoid a hazard.
- The appliance shall be installed in accordance with national wiring regulations.
- Servicing shall only be performed as recommended by the equipment manufacturer.
- Maintenance and repair requiring the assistance of other skilled personnel shall be carried out under the supervision of the person competent in the use of flammable refrigerants.
- Means for disconnection, such as circuit breaker, which can provide full disconnection in all poles, must be incorporated in the fixed wiring in accordance with the wiring rules.
It is necessary to allow the disconnection of the appliance from the supply after installation. Make sure the disconnection of the appliance from the supply when service and maintenance, a disconnection with a locking system in the isolated position shall be provided.
- The method of connection of the appliance to the electrical supply and interconnection of separate components, and the wiring diagram with a clear indication of the connections and wiring to external control devices and supply cord are detailed in below parts.
- Details of type and rating of circuit breakers / ELB is detailed in below parts.
- The information of dimensions of the space necessary for correct installation of the appliance including the minimum permissible distances to adjacent structures is detailed in below parts.
- This appliance is intended to be used by expert or trained users in shops, in light industry and on farms, or for commercial use by lay persons.
- Instructions on additional charging of refrigerants are detailed below.

Diagram of refrigerant cycle & Wiring

Refrigerant flow diagram

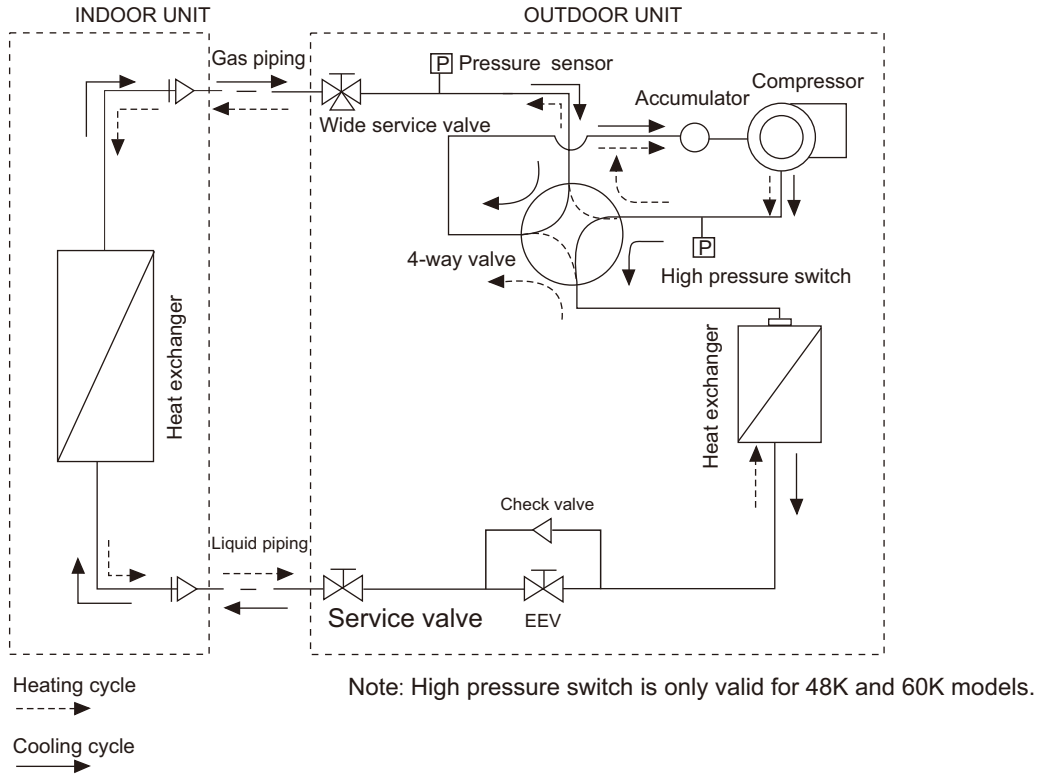

Electrical wiring diagram

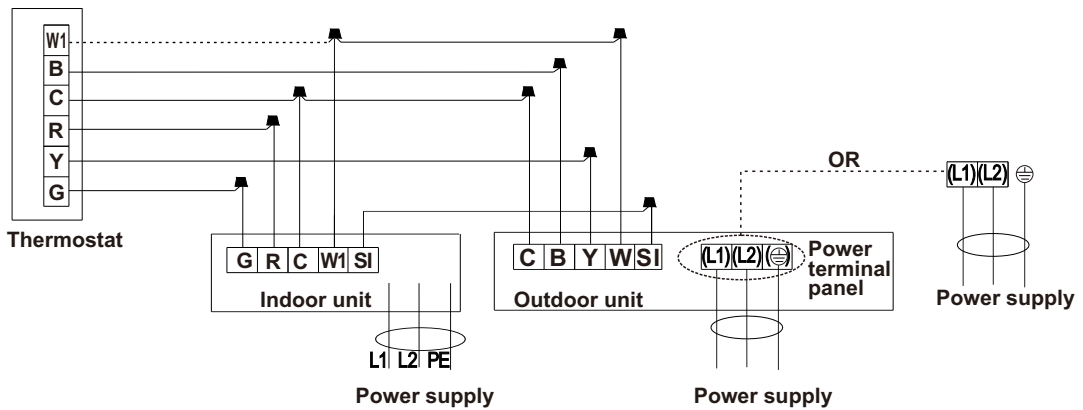

Note:

The SI wire between the indoor and outdoor units is not indispensable, especially when the outdoor unit is connected to an indoor unit of a different brand. It is more energy-saving when the outdoor unit is connected to an indoor unit of the same brand by SI wire. However, it still can run without it.

Installation instructions

Transportation and handling before installation

Transport the product as close to the installation location as practical before unpacking.

• Handling Method

When handling the unit, ensure a balance of the unit, check safety and lift it up smoothly.

- (1) Do not remove any packing materials.
- (2) Hang the unit under packing condition with two ropes, as shown in Fig. blow.

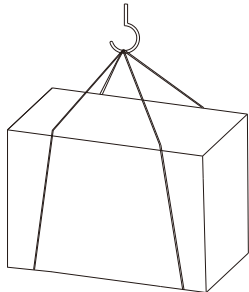

• Handling

If have no package to move, please protect with cloth or paper.

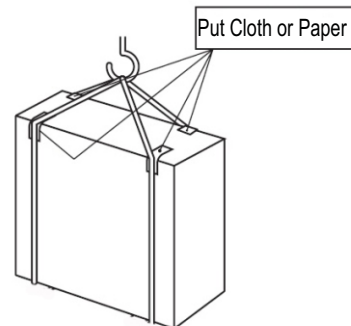

Installation locations selection

Before choosing the installation site, obtain user's approval.

- Where it is not exposed to strong wind.
- Where airflow is good and clean.
- Where it is not exposed to rain and direct sunshine.
- Where neighbors are not annoyed by operation sound or hot air.
- Where rigid wall or support is available to prevent the increase of operation sound or vibration.
- Where there is no risk of combustible gas leakage.
- Where it is at least 3m away from the antenna of TV set or radio. An amplifier may be required for the affected device.
- Install the unit horizontally.
- Please install it in an area not affected by snowfall or blowing snow. In areas with heavy snow, please install a canopy, a pedestal and/or some baffle boards.

⚠ CAUTION:

Avoid the following places for installation where air conditioner trouble is liable to occur.

- Where there is much machine oil.
- Salty places such as seaside.
- Where sulfide gas is generated such as a hot spring.
- Where there is high-frequency or wireless equipment.

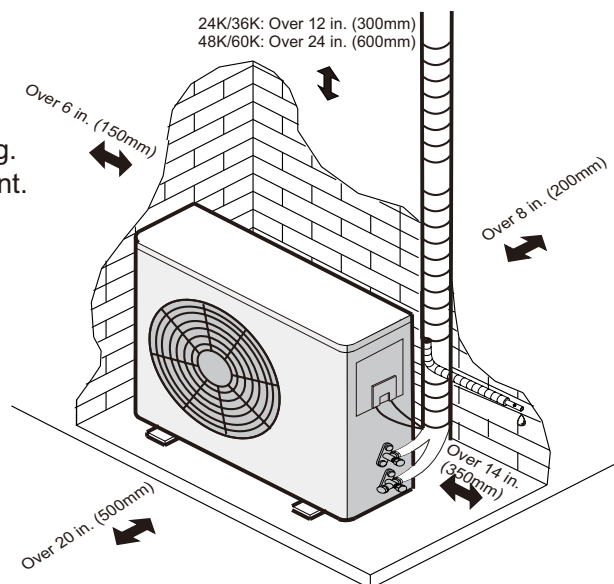

NOTE:

When operating the air conditioner in low outside temperature, be sure to follow the instruction described below.

- Never install the outdoor unit in a place where its air inlet/outlet side may be exposed directly to wind.
- To prevent exposure to wind, install the outdoor unit with its air inlet side facing the wall.
- To prevent exposure to wind, it is recommended to install a baffle board on the air outlet side of the outdoor unit.

Installation instructions

Drainage elbow and drain hose installation

Install Drainage Elbow and Drain Hose

- The condensate water may drain from the outdoor unit when the unit operates in heating mode. In order to avoid disturbing neighbors and protect the environment, it is necessary to install a drainage elbow and a drain hose to drain out the condensate water.
- Please do the drainage work before the indoor unit and outdoor unit are connected. Otherwise, it will be difficult to install drainage elbow after the machine becomes immovable.)
- Connect the drain hose(field-supplied, inside diameter: 15mm) as shown in the figure for drainage.

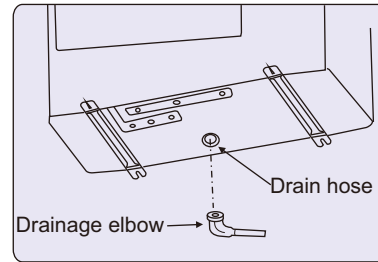

NOTE:

Do not use the drainage elbow in the cold region. Drain may freeze to stop the fan runs.

Outdoor unit installation

- (1) Use the washers to fasten the machine at the foundation bolts.
- (2) When fastening the outdoor unit with the foundation bolts, the fasten holes position is shown as the Fig.1.
- (3) Fasten the outdoor unit as the Fig.2.
- (4) Make sure to fasten the outdoor unit tight and horizontal to prevent noise when the machine is oblique or inclined by strong breeze or earthquake.
- (5) Do not drain off water to the public places to avoid to skidding.
- (6) The strong base (made of concrete, etc.) should be made. The appliance should be placed not less than 10 cm high to avoid being wet or corroded. Otherwise, it may cause damage to the appliance or reduce its life time. (Fig.3)

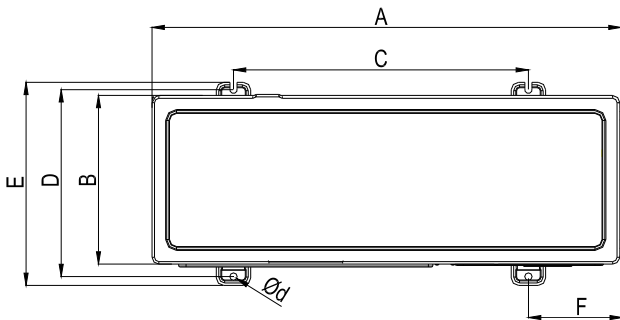

[Unit: in. (mm)]

Model	A	B	C	D	E	F	d
36K	37-3/8 (950)	13-3/8 (340)	22-7/8 (580)	14-15/16 (380)	16-1/4 (414)	7-1/4 (185)	5/8 (15)

Fig.1

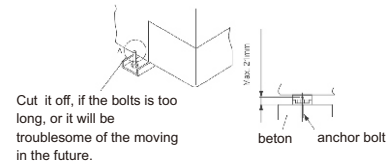

Fig.2

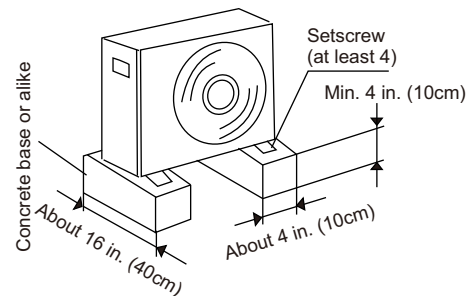

Fig.3

Installation instructions

Refrigerant piping

1. Piping requirement

Model	Outer Diameter of Pipe [in. (mm)]	
	Gas	Liquid
36K	3/4 (19.05)	3/8 (9.52)

The shorter the refrigerant piping is, the better the performance will be. So the connecting pipe should be as short as possible.

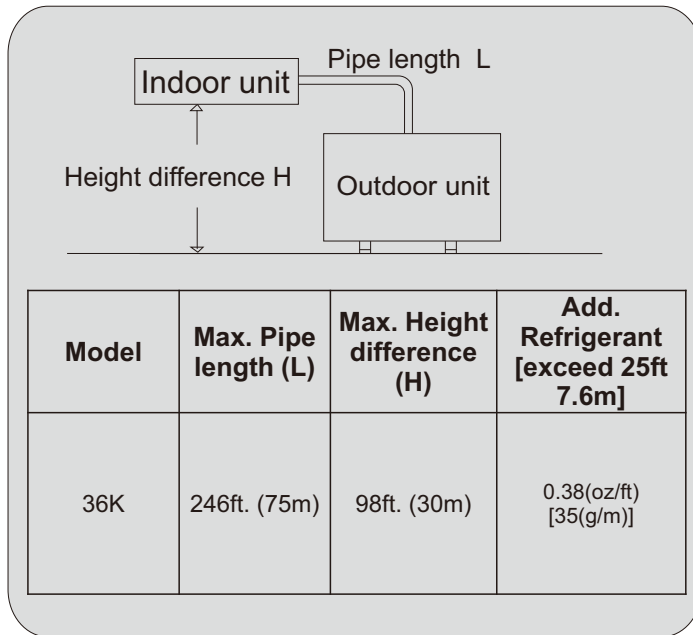

Refrigerant additional charge

The unit has been filled with refrigerant, but if exceeds 25 ft. (7.6m), additional refrigerant (R410A) charge is required.

24K/36K: Additional refrigerant charge= (L-25) ft × 0.38 oz/ft

48K/60K: Additional refrigerant charge= (L-25) ft × 0.60 oz/ft

2. Piping material

- (1) Prepare locally-supplied copper pipes.
- (2) Select clean copper pipes. Make sure that there is no dust and moisture inside of the pipes. Blow the inside of the pipes with nitrogen or dry air to remove any dust or foreign materials before connecting pipes.
- (3) Piping thickness and material of the pipe are shown as below.

Diameter [in. (mm)]	Thickness [in. (mm)]
ø 1/4 (6.35)	1/32 (0.8)
ø 3/8 (9.52)	1/32 (0.8)
ø 1/2 (12.70)	1/32 (0.8)
ø 5/8 (15.88)	1/32 (1.0)
ø 3/4 (19.05)	1/32 (1.0)
ø 7/8 (22.22)	1/32 (1.0)

Installation instructions



CAUTION

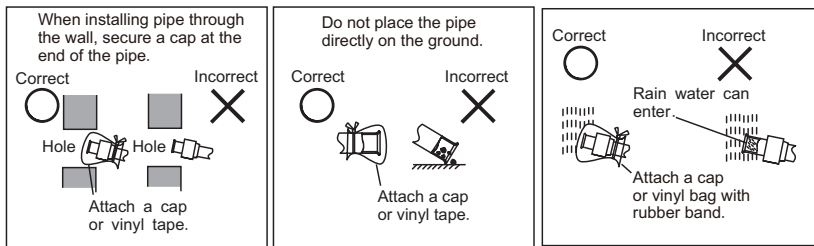

3. Processing of refrigerant piping

(1) Pipe cutting

Cut the copper pipe correctly with pipe cutter.

(2) Burrs removal

Completely remove all burrs from the cut cross section of the pipe.

Put the end of the copper pipe downward to prevent burrs from dropping in the pipe.

4. Piping connection

(1) Confirm that the valves are closed.

(2) Connect the indoor unit and the outdoor unit with field-supplied refrigerant pipes. The refrigerant piping should be brazed with a phosphorous-copper alloy material such as Silfos-5 or equivalent. Precautions and steps during brazing service valve:

- a. Remove the caps from both the liquid and gas service valve service ports at the outdoor unit.
- b. Braze the liquid piping and gas piping to valves at the outdoor unit. Precautions should be taken to prevent heat damage to service valve by wrapping a wet cloth around it. Also, a baffle can be set to protect all painted surfaces, insulation, during brazing.
- c. After brazing cool joint with wet rag.

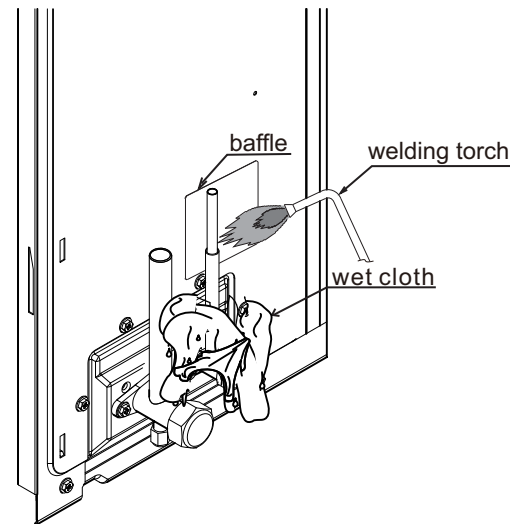

(3) After finishing connecting the refrigerant pipes, keep it warm with the insulation material like figure right.

- For outdoor unit side, surely insulate every piping including valves.
- Cover piping joints with pipe cover.
- Using piping tape, apply taping starting from the entry of outdoor unit.
 - Fix the end of piping tape with adhesive tape.
 - When piping has to be arranged through above ceiling, closet or area where temperature and humidity are high, wind additional commercially sold insulation for prevention of condensation.

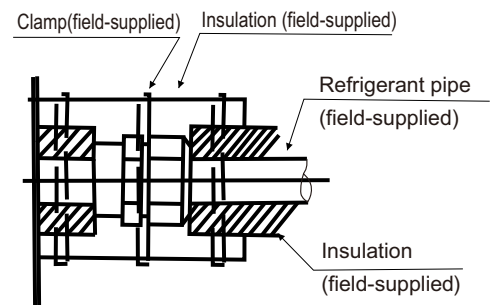

Piping insulation procedure

5. Air tight test

- Do use Nitrogen.

Connect the gauge manifold using charging hoses with a nitrogen cylinder to the check joints of the liquid line and the gas line stop valves.

Perform the air-tight test.

Don't open the gas line stop valves.

Apply nitrogen gas pressure of 550 psig (3.8 MPa).

Check for any gas leakage at the flare nut connections, or brazed parts by gas leak detector or foaming agent.

Gas pressure doesn't decrease is OK.

After the air tight test, release nitrogen gas.

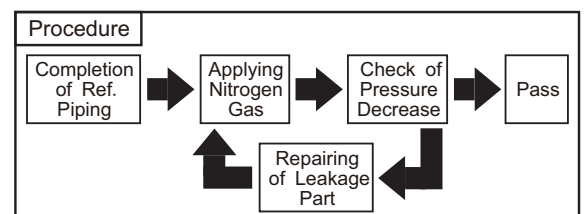

Air tight procedure

Installation instructions

6. Vacuum pumping and charge refrigerant

• Vacuum pumping

- (1) Remove the service port cap of the stop valve on the gas pipe side of the outdoor unit.
- (2) Connect the manifold gauge and vacuum pump to the service port of the stop valve on the gas pipe side of the outdoor unit.
- (3) Run the vacuum pump. (Work for more than 15 minutes.)
- (4) Check the vacuum with the gauge manifold valve, then close the gauge manifold valve and stop the vacuum pump.
- (5) Leave it as is for one or two minutes. Make sure the pointer of the manifold gauge remains in the same position. Confirm that the pressure gauge shows -14.7 psig (-0.101 MPa or -760 mmHg).
- (6) Remove the manifold gauge quickly from the service port of the stop valve.
- (7) After refrigerant pipes are connected and evacuated, fully open all stop valves on both sides of gas pipe and liquid pipe.
- (8) Open adjusted valve to add refrigerant (must be refrigerant is liquid).
- (9) Tighten the cap to the service port .
- (10) Re-tighten the cap.
- (11) Leak test foam with halogen leak detector to check the flare nut and brazing Carolina Department leaks. Use foam that not generate ammonia (NH_3) in the reaction.

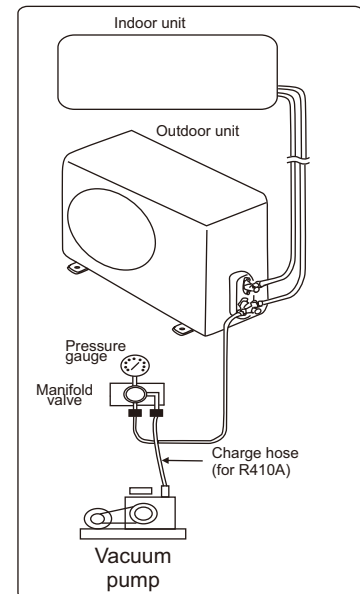

CAUTION

- An excess or a shortage of refrigerant is the main cause of trouble to the unit. Charge the correct refrigerant quantity according to the description of label at the inside of the manual.
- Check for refrigerant leakage in detail. If a large refrigerant leakage occurs, it will cause difficulty with breathing or harmful gases would occur if a fire was being used in the room.

• Additional refrigerant charge

The unit has been filled with refrigerant.

Please according "Piping Requirement" to calculate additional charge.

After vacuum pump procedure has been finished, first exhaust air from charge hose, then open valves, charge refrigerant as "liquid" type through Liquid stop valve.

At the end, please close valves and record the refrigerant charging quantity.

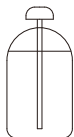

Filling a cylinder with an attached siphon

Stand the cylinder upright when filling.

(Stand the cylinder upright when filling.
There is a siphon pipe inside, so the cylinder
need not to be upside-down to fill with liquid.)



Filling other cylinders

Turn the cylinder upside -down when filling.

Installation instructions

Wiring



WARNING

- Turn OFF the main power switch to the indoor unit and the outdoor unit and wait for more than 3 minutes before electrical wiring work or a periodical check is performed.
- Check to ensure that the indoor fan and the outdoor fan have stopped before electrical wiring work or a periodical check is performed.
- Protect the wires, electrical parts, etc. from rats or other small animals. If not protected, rats may gnaw at unprotected parts and at the worst, a fire will occur.
- Avoid the wirings from touching the refrigerant pipes, plate edges and electrical parts inside the unit. If not do, the wires will be damaged and at the worst, a fire will occur.
- Install an ELB (Electric Leakage Break) in the power source. If ELB is not used, it will cause electric shock or fire at the worst.
- This unit uses an inverter, which means that it must be used an earth leak detector capable handling harmonics in order to prevent malfunctioning of the earth leak detector itself.
- Do not use intermediate connection wires, stranded wires (see **<Attentions when Connect the power supply wiring>**), extension cables or control line connection, because the use of these wires may cause fever, electric shock or fire.
- The tightening torque of each screw shall be as follows.
 - M4: 0.7 to 1.0 lbf·ft. (1.0 to 1.3 N·m)
 - M5: 1.5 to 1.8 lbf·ft. (2.0 to 2.5 N·m)
 - M6: 3.0 to 3.7 lbf·ft. (4.0 to 5.0 N·m)
 - M8: 6.6 to 8.1 lbf·ft. (9.0 to 11.0 N·m)
 - M10: 13.3 to 217 lbf·ft. (18.0 to 23.0 N·m)Keep the above tightening torque when wiring work.



CAUTION

- With tape material along the wire wrapped, sealed wiring holes, prevent the condensed water and insects.
- Tightly secure the power source wiring using the cord clamp inside the unit.
Note: Fix the rubber bushes with adhesive when conduit tubes to the outdoor unit are not used.

General check

- (1) Make sure that the field-selected electrical components (main power switches, circuit breakers, wires, conduit connectors and wire terminals) have been properly selected according to the electrical data.
Make sure that the components comply with National Electrical Code (NEC).
- (2) Check to ensure that the voltage of power supply is within +10% of nominal voltage and earth phase is contained in the power supply wires. If not, electrical parts will be damaged.
- (3) Check to ensure that the capacity of power supply is enough.
If not, the compressor will be not able to operate cause of voltage drop abnormally at starting.
- (4) Check to ensure that the earth wire is connected.
- (5) Install a main switch, multi-pole main switch with a space of 0.14 in. (3.5mm) or more, single phase main switch with a space of 0.12 in. (3.0mm) or more between each phase.
- (6) Check to ensure that the electrical resistance is more than 2 MΩ, by measuring the resistance between ground and the terminal of the electrical parts. If not, do not operate the system until the electrical leakage is found and repaired.

Installation instructions

Wires connect steps:

36K

(1) Electric box cover removal

Unscrew the mounting screws to remove the electric box cover.

(2) Fasten the power supply cable and the transmitting cable to the conduit holder using the lock nut.

(3) Connect the power supply cable and the transmitting cable to terminal.

(4) Fasten the power supply cable and the connection cable with the cable clamp.

(5) Be sure to seal the holes when applying the putty.

Place the cables side to side. (Do not overlap the cables.)

(6) Put the electric box cover back after completion of the work.

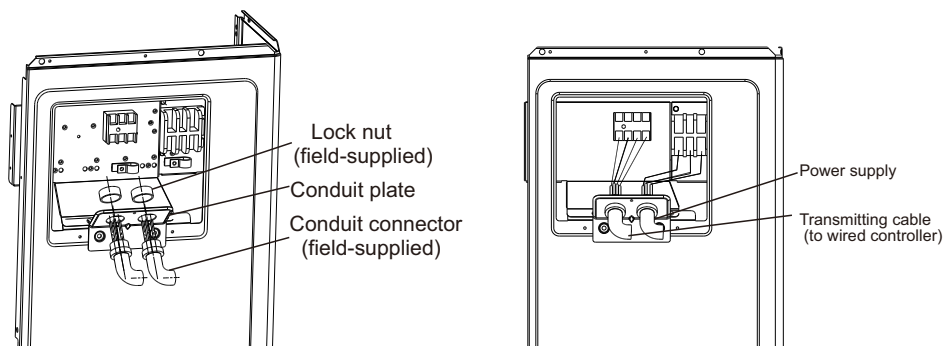

Installation instructions

Electrical Data

Model (Capacity)	Power Supply	ELB		Power Source Cable Size	Transmitting Cable Size	Circuit Breaker (A)
		Rated Current (A)	Nominal Sensitive Current (mA)			
36K	208/230V ~/60Hz	35	30	3×10AWG	5×16AWG	35

Max. Running Current (A): REFER TO NAMEPLATE

Note:

- (1) Follow local codes and regulations when select field wires ,and all the above are the minimum wire size.
- (2) When transmitting cable length is longer than 262ft. (80m), a larger wire size should be selected.
- (3) Install main switch and ELB for each system separately. Select the high response type ELB that is acted within 0.1second.
Recommended capacity to see outdoor machine switch capacity.

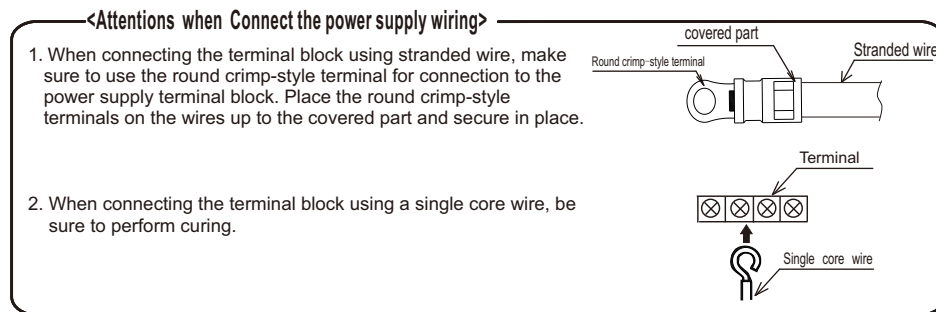

Test run

Test run should be performed after refrigerant piping, drain, wiring, etc. have been finished.



The air conditioner is provided with a crankcase heater, check to ensure that the switch on the main power source has been ON for more than 6 hours ahead of power on preheating, otherwise it might damage the compressor!

Do not operate the system until all the check points have been cleared.

- (A) Check to ensure that the stop valves of the outdoor unit are fully opened.
- (B) Check to ensure that the electric wires have been fully connected.
- (C) Check to ensure that the electrical resistance is more than 2MΩ, by measuring the resistance between ground and the terminal of the electrical parts. If not, do not operate the system until the electrical leakage is found and repaired.

Test run function identification

Operate the thermostat to turn ON the appliance, and then proceed test run.

Pay attention to the following items while the system is running.

Do not touch any of the parts by hand at the discharge gas side, since the compressor chamber and the pipes at the discharge side are heated higher than 194°F (90°C) .

- Turn off the power after test run is finished.

Installation of the appliance is generally finished after the above operations are done. If you still have any trouble, please contact local technical service center of our company for further information.

Limited Warranty provided by Comfortside, LLC. (hereby referred to as Comfortside) applies only to registered products installed by a licensed HVAC technician and covers specified products and parts, subject to the following details:

Product Registration: Products must be registered for Limited Warranty within 60 days of installation by licensed HVAC technician. Products can be registered at olmo-comfort.com. Alternatively, the warranty registration card from the product User's Manual can be filled out and sent in as instructed.

Warranty Coverage: The warranty covers the parts of the products which may be defective due to the quality of the materials or workmanship, under normal use and proper maintenance. Warranty is provided only to the first original owner of the Product, where it is originally installed, and is not transferable to the subsequent owners.

Warranty Exclusions: Comfortside is not responsible for any warranty claim:

1. For equipment installed outside of North America.
2. For equipment not installed according to manufacturer's guidelines.
3. For equipment which has been removed from the original site of installation and reinstalled at another location.
4. If registration information cannot be verified (i.e., invalid license number or wrong information provided).
5. Regarding damages or repairs arising as a result of a faulty installation, inappropriate application, or improper use.
6. Regarding damages or repairs arising from any external perils, out of Comfortside's control, acts of nature such as fires, storms, accidents, floods, broken or frozen water pipes, electrical surges, input power with under or overvoltage, lightning, or existence of corrosive substances nearby.
7. Regarding damages or repairs arising from use of non-compatible parts, third-party components, alterations, modifications, or improper applications.
8. Regarding improper service or poor maintenance of the equipment, such as cleaning of all air filters, heat exchangers, fans, and blowers, in addition to any necessary lubrication of internal components and maintenance of external accessories.
9. Regarding changes that can be considered cosmetic, including but not limited to small fin damages, scratches on the unit cover, etc.
10. Regarding resetting of power or the circuit breakers and replacement of other types of fuses, both internal and external.
11. Regarding any damage caused using dirty, recycled, or wrong type of refrigerants and lubricants.
12. Regarding damage due to moisture, air, dust, sand, dirt, etc., that have been allowed into the system.
13. Regarding damage caused by continuing use of the product after a malfunction has been noticed or indicated at the display module, through an error code.
14. Regarding damages or performance issues due to improper matching, product selection, under-sizing, over-sizing, improper installation, or misuse.
15. Regarding loss or replacement of refrigerant, lubricant, or oil.
16. Regarding labor or any costs associated with labor.

Warranty Begin Date: Warranty begins on the date of registration.

Warranty End Date: Products that have not been registered as instructed above are not covered under Warranty. The length of your Warranty depends on the specific model unit you have purchased. Information on Warranty length is available online, by visiting olmo-comfort.com. As further explained below in detail, coverage is only for the original registered user who owns and resides in the dwelling or operates business in the property in which the product is installed.

Remaining Warranty: Any part, component or product that is replaced under the terms of the Warranty, will be covered under the same Warranty for the duration in which the original Warranty for the product is applicable.

Warranty Procedure: Comfortside will furnish a new or refurbished part, without any charge for the part itself, for the replacement of any part that has been determined to have failed, by Comfortside at its sole discretion, due to defects in its materials or workmanship under standard use and proper maintenance. The payment of the shipping costs for the part will be the sole responsibility of the owner of the product. Comfortside reserves the right to ask the owner of the product to return the failed part before or after a replacement part is sent out. The product owner or technician should contact Comfortside Technical Support at (786) 953-6706, Monday to Friday from 9AM to 5PM Eastern Time, while the technician is on site, servicing the unit. The product may or may not display error codes. The technician should be on site while troubleshooting with the Comfortside Technical Support Agent so he or she can address symptoms observed, specific electrical and mechanical measurements, and other detailed information that may be required for proper diagnosis.

While technicians may refer to Comfortside's website or YouTube channel for helpful information, such as manuals and videos based on certain error codes, the technician will need to troubleshoot with the Technical Support Agent for Warranty purposes. Comfortside is not able to remotely diagnose a product and/or offer remedies, without proper diagnosis results.

When contacting Technical Support, a licensed technician must be onsite, and the following information needs to be provided:

- The Serial Number of the unit.
- The product purchase invoice and an installation invoice from licensed HVAC technician.
- Case number (if applicable) provided during previous Technical Support call(s).
- Comfortside may ask for photos and/or other diagnostic information it deems necessary prior to processing the Warranty claim.

It should be noted that Comfortside Technical Support Agents troubleshoot on a case-by-case basis, following best practices and procedures to diagnose problems and solutions. Through this process, it is most efficient to diagnose one issue or error code at a time. It is possible that the first suggested solution may or may not solve one problem of multiple failures, in which case the Technician will continue through troubleshooting for remaining issues/error codes.

Labor cost, materials, and other costs: Any labor costs and/or the costs for the supplies or materials used or purchased in the field for the replacement of the defective part, remain the responsibility of the owner. No other costs involved in diagnosis, lodging, transportation, servicing, repair, replacement, installation, removal, shipping, etc., are to be covered under the Warranty.

Refrigerant: Any costs related to charging, recharging, adjustment, or removal of refrigerant, and the cost of the refrigerant itself, are not covered under any circumstances. All products go through vigorous quality controls at various stations and leave the factory in perfect working and sealed condition. Products are individually tested in highly sensitive helium vacuum chambers for existence of refrigerant

leaks Comfortside does not cover any claims related to the lack of refrigerant in new products, discovered upon arrival, or during installation, as well as subsequent refrigerant loss occurring at any time afterward.

This Warranty is not transferable. No person or entity is authorized to change the terms and conditions outlined in this Warranty agreement, in any respect, nor to create any additional obligations or liabilities for any party involved.

This warranty agreement supersedes all prior warranty agreements between the parties and constitutes the complete, final, and exclusive understanding of the parties with respect to the subject matter. All prior negotiations, representations, or promises, whether oral or written, of either party shall be deemed to have been merged herein.

If any part of this Warranty Agreement shall be invalidated for any reason, such part shall be deleted, and the remainder shall be unaffected and shall continue in full force and effect. This Warranty provides you certain legal rights and you may also have other rights, which vary from State to State. Therefore, some of these limitations or exclusions may not apply to you.

States with Express and Implied Warranties: Products in states with Express and Implied Warranties do not need to be registered for Comfortside Warranty. However, for Warranty support, installation invoice should be provided.

Pursuing legal remedies:

ARBITRATION CLAUSE. IMPORTANT. PLEASE REVIEW THIS ARBITRATION CLAUSE, AS IT AFFECTS YOUR LEGAL RIGHTS.

1. This arbitration clause affects your rights against Comfortside and any of its employees, agents, affiliates, successors, or assignees, all of whom together are referred to below as “we” or “us” for the simplicity of reference.
2. **ARBITRATION REQUIREMENT: EXCEPT AS STATED BELOW, ANY DISPUTE BETWEEN YOU AND ANY OF US SHALL BE DECIDED BY NEUTRAL AND BINDING ARBITRATION, RATHER THAN ANY COURT OR BY TRIAL BY JURY. ARBITRATION WILL BE HANDLED ONLY ON AN INDIVIDUAL BASIS AND ALL PARTIES EXPRESSLY WAIVE; ANY RIGHTS TO PARTICIPATE AS A CLASS REPRESENTATIVE OR CLASS MEMBER, ANY RIGHTS TO CLASS ARBITRATION OR ANY CONSOLIDATION OF INDIVIDUAL ARBITRATIONS. THE ARBITRATOR WILL BE A MEMBER OF THE AMERICAN ARBITRATION ORGANIZATION.** The meaning of “Dispute” has the broadest possible meaning allowable by law, including any controversy, claim or other dispute, relating to or arising from the purchase of the product, any of the warranties upon the product, or the condition of the product, as well as the determination of the application or the scope of the Arbitration Clause itself. Rights to appeal and discovery are also limited in arbitration based on the rules of the arbitration organizations.
3. **Governing Law:** Effect and procedures of arbitration will be governed by the Federal Arbitration Act (9 U.S.C. § et seq.) rather than any related state law. In case of any substantive warranty, your claims and rights under such substantive warranty will be governed by the applicable law of the state in which Product was purchased.
4. **Location of the Arbitration:** Unless otherwise provided under the applicable law, arbitration hearing will be conducted in the judicial district in Miami-Dade County, Florida.
5. **Costs of the Arbitration:** Unless otherwise provided under the applicable law, each party will be responsible for its own cost, payable to the arbitration organization, and the costs of their attorneys, experts or other fees.
6. **Survival and Enforceability of the Arbitration Clause:** This arbitration clause will survive the expiration or termination of this warranty agreement, indefinitely.

